

Electricity and chemistry

Question Paper 4

Level	IGCSE
Subject	Chemistry
ExamBoard	CIE
Topic	Electricity and chemistry
Sub-Topic	
Paper	(Extended) Theory
Booklet	Question Paper 4

TimeAllowed: 68 minutes

Score: / 56

Percentage: /100

1 Aluminium is extracted by the electrolysis of a molten mixture that contains alumina, which is aluminium oxide, Al_2O_3 .

(a) The ore of aluminium is bauxite. This contains alumina, which is amphoteric, and iron(III) oxide, which is basic. The ore is heated with aqueous sodium hydroxide. Complete the following sentences.

The dissolves to give a solution of

The does not dissolve and can be removed by [4]

(b) Complete the labelling of the diagram.

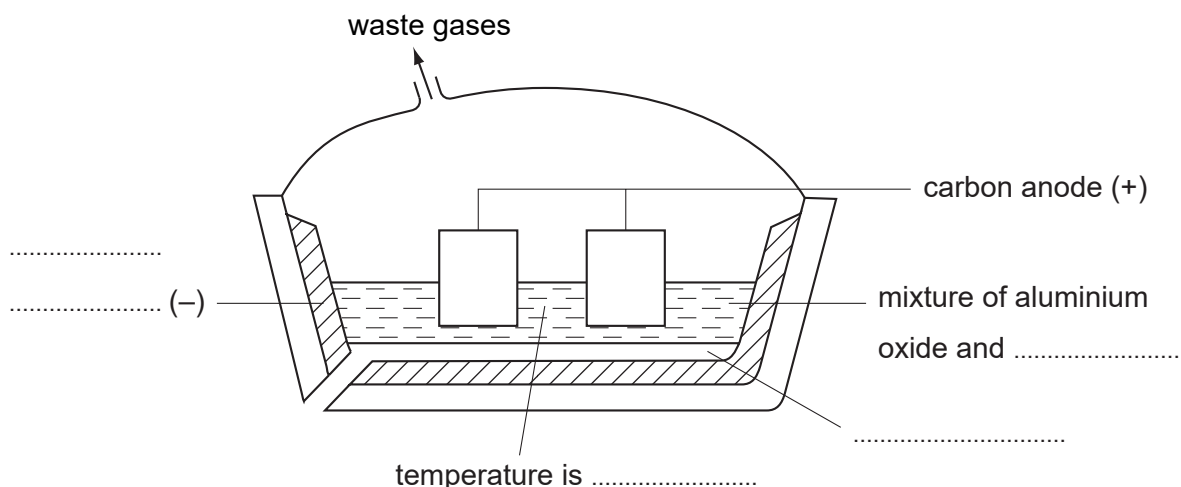

[4]

(c) The ions that are involved in the electrolysis are Al^{3+} and O^{2-} .

(i) Write an equation for the reaction at the cathode.

..... [2]

(ii) Explain how carbon dioxide is formed at the anode.

..... [2]

(d) Give an explanation for each of the following.

(i) Aluminium is used extensively in the manufacture of aircraft.

..... [1]

(ii) Aluminium is used to make food containers.

..... [2]

(iii) Aluminium electricity cables have a steel core.

..... [1]

[Total: 16]

2 The position of aluminium in the reactivity series of metals is shown below.

magnesium
aluminium
zinc
copper

(a) Aluminium is extracted by the electrolysis of its molten oxide.

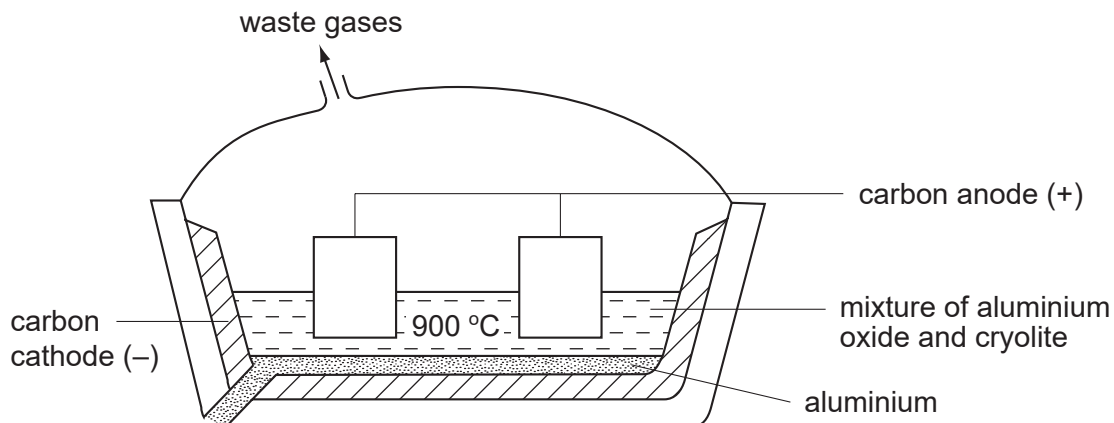

(i) Name the main ore of aluminium.

..... [1]

(ii) Why does the molten electrolyte contain cryolite?

..... [1]

(iii) Oxygen is produced at the positive electrode (anode). Name another gas which is given off at this electrode.

..... [1]

(b) Aluminium reacts very slowly with aqueous copper(II) sulphate.



(i) Which of the two metals has the greater tendency to form ions?

..... [1]

(ii) Describe what you would see when this reaction occurs.

..... [1]

(iii) Explain why aluminium reacts so slowly.

..... [1]

(c) Complete the following table by writing “reaction” or “no reaction” in the spaces provided.

oxide	type of oxide	reaction with acid	reaction with alkali
magnesium	
aluminium	am

[2]

(d) Predict the equations for the decomposition of the following aluminium compounds.

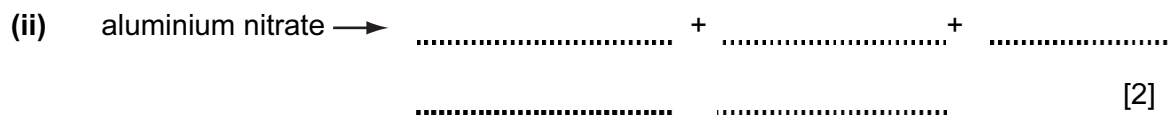

- 3 (a) Copper has the structure of a typical metal. It has a lattice of positive ions and a “sea” of mobile electrons. The lattice can accommodate ions of a different metal.

Give a **different** use of copper that depends on each of the following.

- (i) the ability of the ions in the lattice to move past each other

..... [1]

- (ii) the presence of mobile electrons

..... [1]

- (iii) the ability to accommodate ions of a different metal in the lattice

..... [1]

- (b) Aqueous copper(II) sulphate solution can be electrolysed using carbon electrodes. The ions present in the solution are as follows.

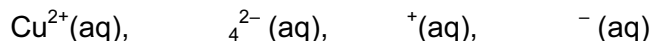

- (i) Write an ionic equation for the reaction at the negative electrode (cathode).

..... [1]

- (ii) A colourless gas was given off at the positive electrode (anode) and the solution changes from blue to colourless.

Explain these observations.

.....
..... [2]

(c) Aqueous copper(II) sulphate can be electrolysed using copper electrodes. The reaction at the negative electrode is the same but the positive electrode becomes smaller and the solution remains blue.

(i) Write a word equation for the reaction at the positive electrode.

..... [1]

(ii) Explain why the colour of the solution does not change.

.....
..... [2]

(iii) What is the large scale use of this electrolysis?

..... [1]

4 Hydrogen can be manufactured from methane by steam reforming.

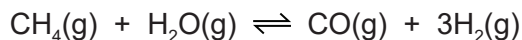

The reaction is carried out using a nickel catalyst at temperatures between 700 °C and 1100 °C and using a pressure of one atmosphere.

The forward reaction is endothermic.

(a) What is meant by the term *catalyst*?

.....
..... [2]

(b) Suggest **two** reasons why a temperature lower than 700 °C is not used.

.....
..... [2]

(c) Suggest **one** advantage of using a pressure greater than one atmosphere.

..... [1]

(d) Suggest **one** disadvantage of using a pressure greater than one atmosphere.

..... [1]

(e) Hydrogen can also be manufactured by electrolysis. The electrolyte is concentrated aqueous sodium chloride. The electrodes are inert.

The products of electrolysis are hydrogen, chlorine and sodium hydroxide.

(i) *electrolysis*.

.....
..... [2]

(ii) Name a substance that can be used as the inert electrodes.

..... [1]

(iii) Write an ionic half-equation for the reaction in which hydrogen is produced.

..... [1]

(iv) Where is hydrogen produced in the electrolytic cell?

..... [1]

(v) Describe a test for chlorine.

test

result

[2]

(f) The electrolysis of concentrated aqueous sodium chloride can be represented by the following word equation.

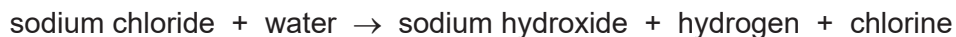

Construct a chemical equation to represent this reaction. Do not include state symbols.

..... [2]

(g) State one use of

chlorine,

sodium hydroxide,

hydrogen.

[3]

[Total: 18]