

Simple Kinetic Molecular Model of Matter

Question Paper 1

Level	IGCSE
Subject	Physics
Exam Board	CIE
Topic	Thermal Physics
Sub-Topic	Simple Kinetic Molecular Model of Matter
Paper Type	Alternative to Practical
Booklet	Question Paper 1

Time Allowed: 52 minutes

Score: /43

Percentage: /100

- 1 Some students are comparing the rates of cooling of two thermometer bulbs under wet and dry conditions.

They are using the apparatus shown in Fig. 1.1.

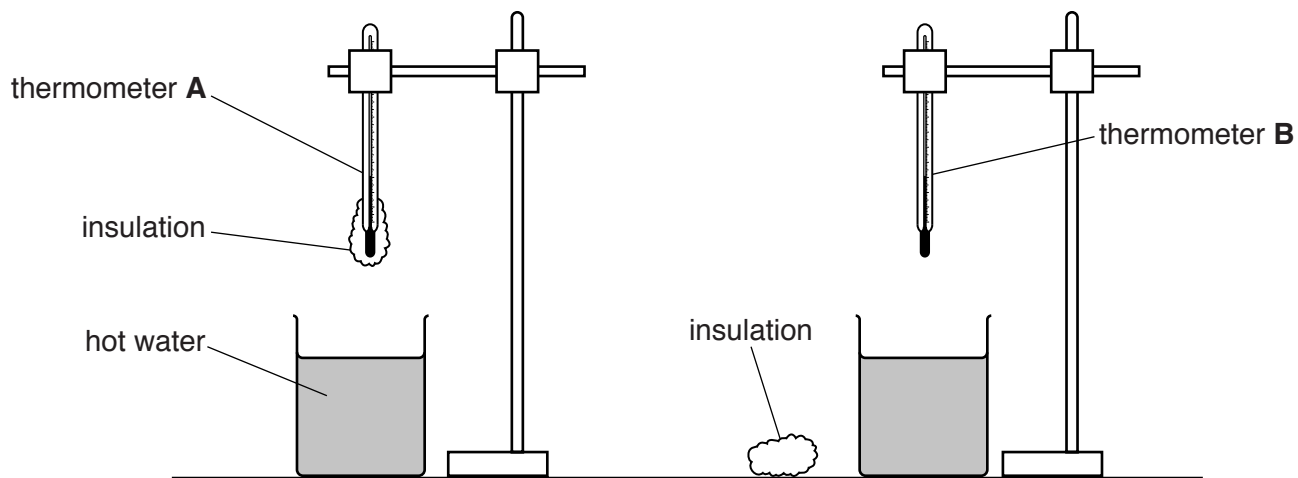

Fig. 1.1

Thermometer **A** has a layer of cotton wool insulation fixed around the bulb.

- (a) Record the room temperature θ_R , as shown on the thermometer in Fig. 1.2.

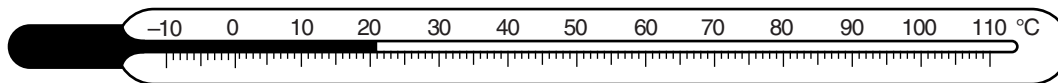

Fig. 1.2

$\theta_R = \dots\dots\dots[1]$

- (b) • Thermometer **A** is placed into hot water, at 81.0 °C, for two minutes and then removed.
- A student records, in Table 1.1, the temperature θ of the thermometer bulb every 30 s.
- Thermometer **B** is placed into hot water, also at 81.0 °C, for two minutes.
- The student removes thermometer **B** from the water and quickly wraps a layer of dry cotton wool insulation around the bulb.
- He then records the temperature θ of the thermometer bulb every 30 s.

Complete the column headings and time column in Table 1.1.

Table 1.1

	thermometer A with wet insulation	thermometer B with dry insulation
time/		
0	80.0	77.5
	75.0	70.5
	67.0	64.0
	59.5	59.0
	53.5	54.5
	48.0	50.5
	43.0	47.5

[2]

- (c) (i) Write a conclusion to this experiment, stating for which thermometer the cooling is faster. Explain your answer by reference to the results.

.....

.....

.....

.....

.....

.....[2]

- (ii) Describe what is unusual about the pattern of cooling for thermometer **A**.

.....

.....

.....[1]

(d) The student first wrapped dry insulation around the bulb of thermometer **B** before starting the timing.

(i) Suggest why he did this.

.....
.....
.....[1]

(ii) Suggest what problem this delay in starting the timing might have caused with the procedure.

.....
.....
.....[1]

(e) Suggest two factors which should be kept constant to ensure that the comparison is fair.

1.
.....
2.
.....
[2]

[Total: 10]

2 The class is investigating the cooling of water.

Fig. 2.1 shows some of the apparatus used.

(a) A student measures the initial temperature of hot water in a beaker, as indicated by the thermometer in Fig. 2.1.

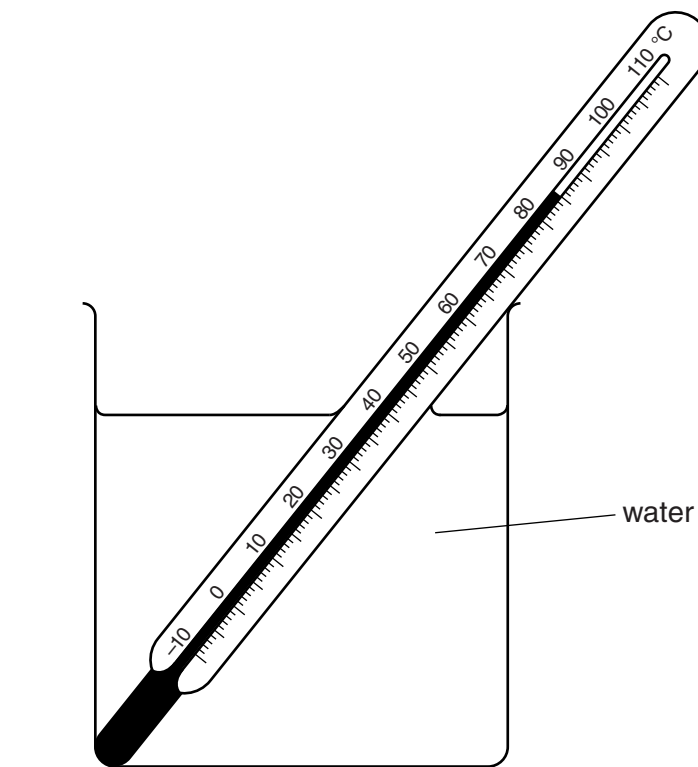

Fig. 2.1

Record this initial temperature in the first row of Table 2.1.

(b) The student allows the water in the beaker to cool and records the temperature at 30s intervals. The readings are shown in the table.

Complete the column headings in the table.

Table 2.1

$t/$	$\theta/$
0	
30	72
60	64
90	60
120	57
150	56

(c) Plot a graph of $\theta/^\circ\text{C}$ (y -axis) against t/s (x -axis).

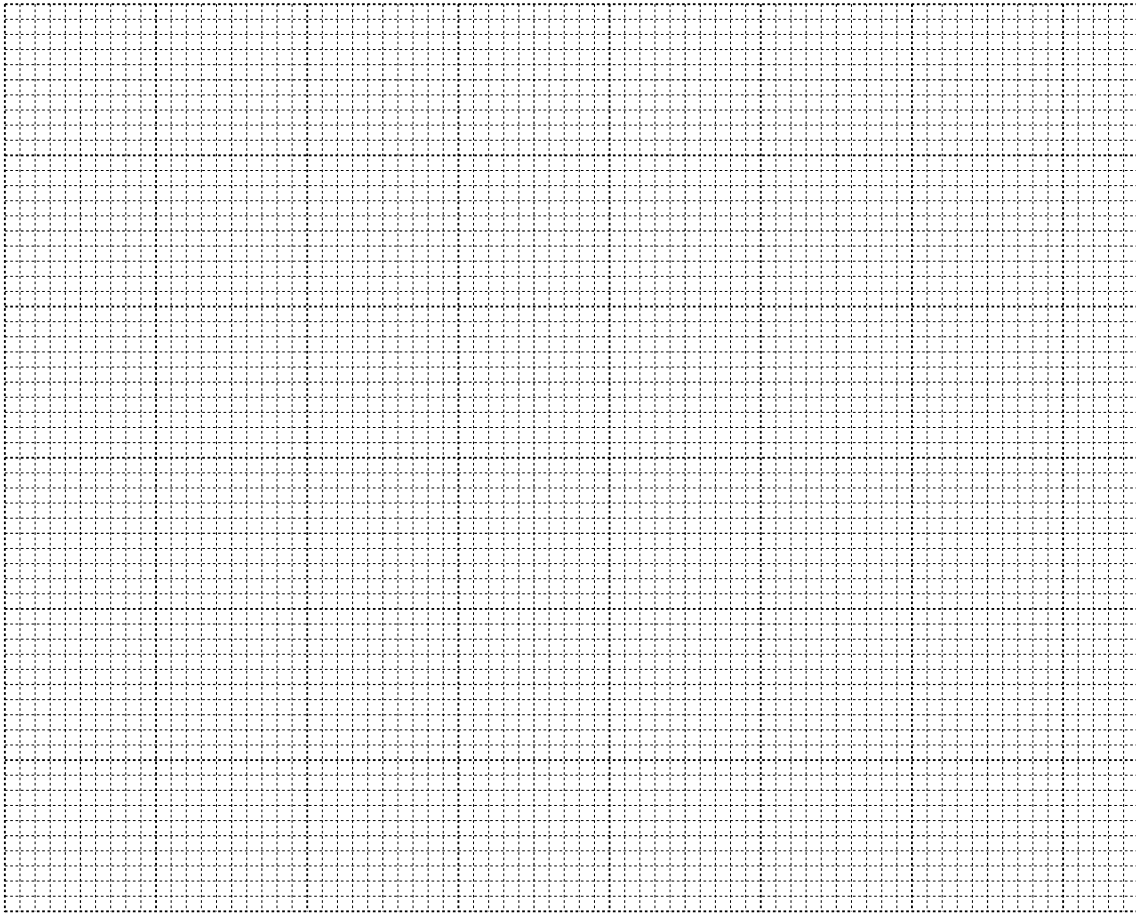

[5]

(d) (i) State whether the rate of cooling of the water in the beaker increases, decreases or stays approximately constant during the period of cooling.

The rate of cooling of the water [1]

(ii) Justify your statement by reference to the graph.

.....
.....
..... [1]

[Total: 9]

3 A student is studying the cooling of water.

She is using the apparatus shown in Fig. 2.1.

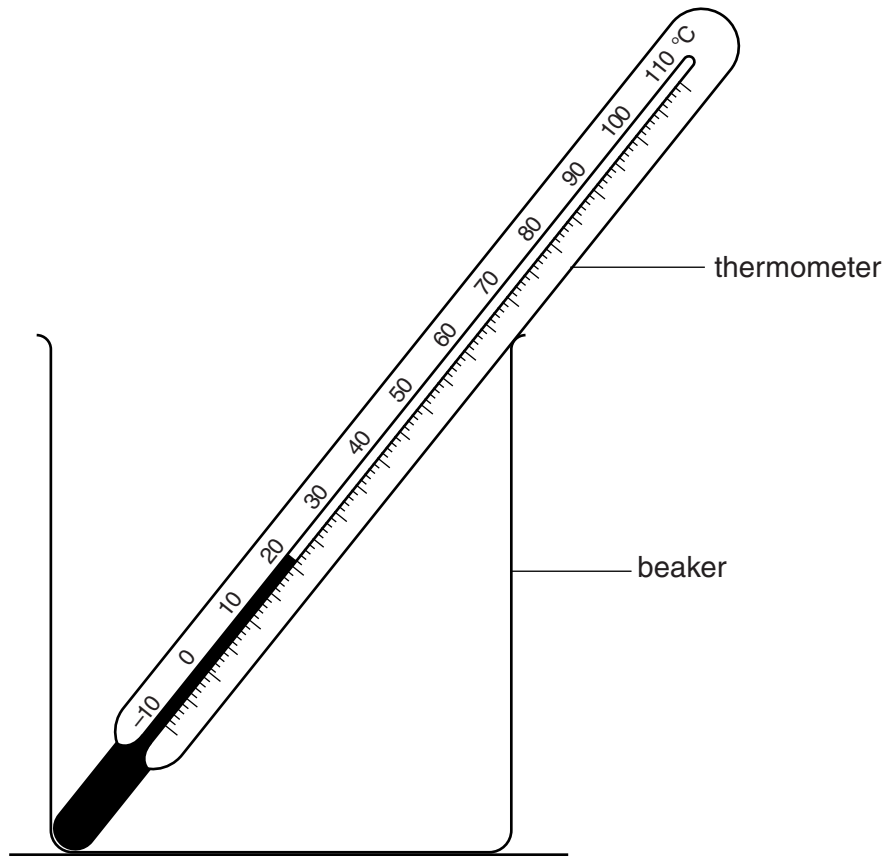

Fig. 2.1

(a) Record the room temperature θ_R as indicated by the thermometer in Fig. 2.1.

$\theta_R = \dots\dots\dots$ [1]

(b) The student pours approximately 100 cm³ of hot water into the beaker.

She reads the thermometer at the start of the experiment and again at times $t = 30\text{ s}$, 60 s , 90 s , 120 s , 150 s , 180 s , 210 s , 240 s and 270 s .

Her readings of the temperature θ are shown in Table 2.1.

Complete the table.

Table 2.1

t/s	$\theta/^\circ\text{C}$
0	85.0
	82.0
	80.0
	77.5
	75.5
	74.0
	72.0
	70.5
	69.0
	67.5

[1]

(c) (i) Calculate the average cooling rate x_1 for the first 90 s of the experiment. Use the readings from the table and the equation $x_1 = \frac{(\theta_0 - \theta_{90})}{T}$, where $T = 90\text{ s}$ and θ_0 and θ_{90} are the temperatures at 0 s and 90 s. Give the unit for the cooling rate.

$x_1 = \dots\dots\dots$ [2]

- (ii) Calculate the average cooling rate x_2 in the next 90s of the experiment. Use the readings from the table and the equation $x_2 = \frac{(\theta_{90} - \theta_{180})}{T}$, where $T = 90\text{s}$ and θ_{90} and θ_{180} are the temperatures at 90s and 180s.

$x_2 = \dots\dots\dots$

- (iii) Calculate the average cooling rate x_3 in the last 90s of the experiment. Use the readings from the table and the equation $x_3 = \frac{(\theta_{180} - \theta_{270})}{T}$, where $T = 90\text{s}$ and θ_{180} and θ_{270} are the temperatures at 180s and 270s.

$x_3 = \dots\dots\dots$ [1]

- (d) Use your results from (c) to predict the average cooling rate x_4 for the next 90s, if the experiment had been carried on for a longer time. Justify your prediction by reference to your results.

prediction for $x_4 = \dots\dots\dots$

justification $\dots\dots\dots$
 $\dots\dots\dots$
 $\dots\dots\dots$ [2]

- (e) State two precautions that you would take in this experiment to ensure that the temperature readings are as reliable as possible.

1. $\dots\dots\dots$
 $\dots\dots\dots$
2. $\dots\dots\dots$
 $\dots\dots\dots$ [2]

[Total: 9]

4 A student is investigating the transfer of thermal energy.

He uses the apparatus shown in Fig. 1.1.

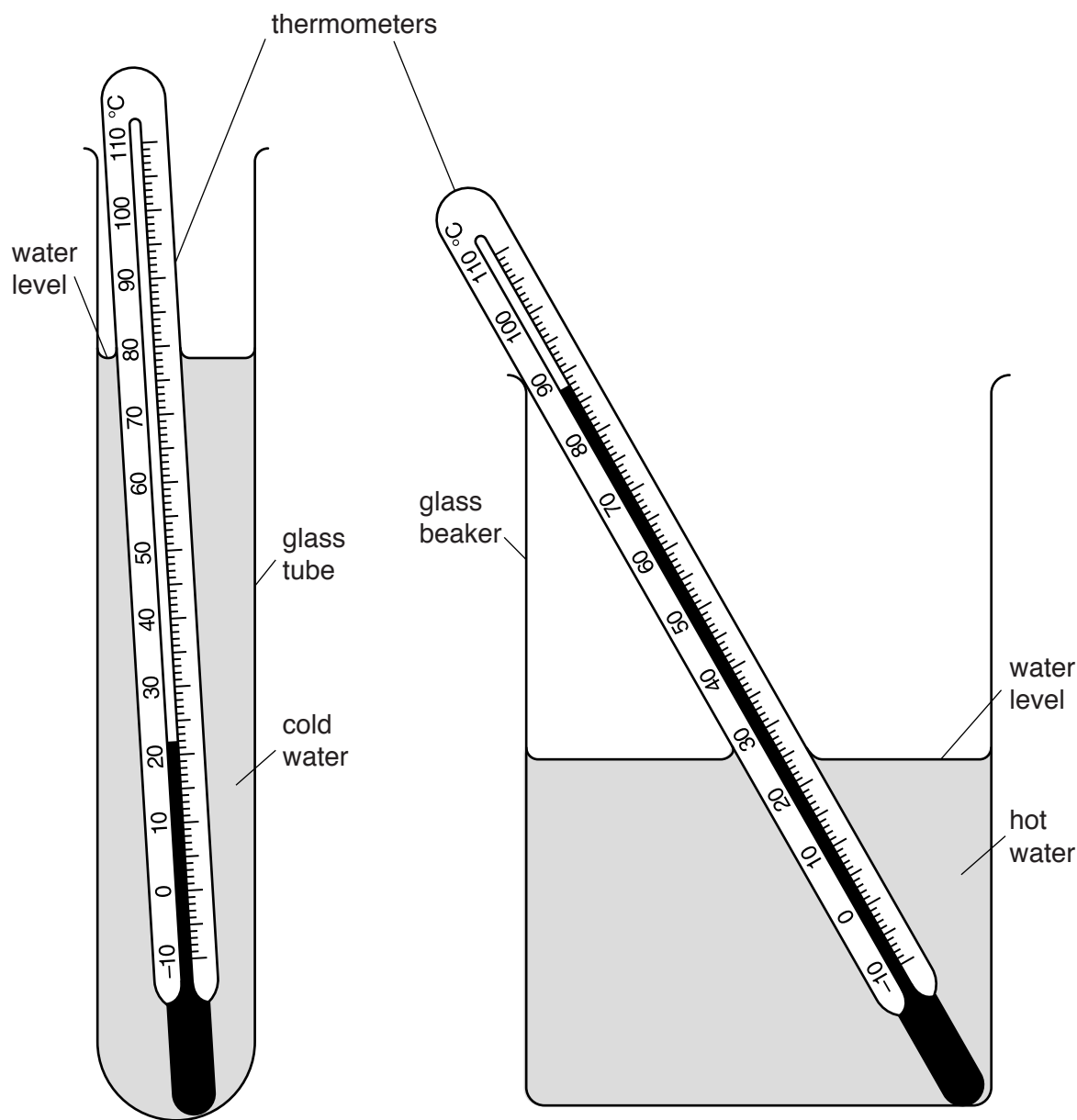

Fig. 1.1

- (a) The student pours 50 cm^3 of cold water into the glass tube and 300 cm^3 of hot water into the beaker. The water levels are approximately as shown in Fig. 1.1.

In Table 1.1, record the temperatures θ_C of the cold water and θ_H of the hot water as shown on the thermometers in Fig. 1.1. [1]

Table 1.1

	tube with 50 cm ³ of cold water		tube with 25 cm ³ of cold water	
<i>t</i> /	θ_C /	θ_H /	θ_C /	θ_H /
0			20.0	87.0
30	33.0	82.0	34.0	82.0
60	40.5	79.0	49.0	79.5
90	49.0	78.0	59.5	76.0
120	56.0	76.0	65.5	75.0
150	60.0	75.0	69.5	74.5
180	63.0	74.0	72.0	74.0

- (b)** The student lowers the glass tube into the beaker of hot water and immediately starts a stopclock.

Table 1.1 shows the readings of the temperature θ_C of the cold water and the temperature θ_H of the hot water at times $t = 30\text{ s}$, 60 s , 90 s , 120 s , 150 s and 180 s .

The student repeats the procedure with the same volume of hot water in the beaker but with 25 cm^3 of cold water in the glass tube. The results are shown in the table.

Complete the column headings in the table. [1]

- (c)** Write a conclusion stating how the volume of cold water in the tube affects its temperature rise.

.....

 [1]

- (d)** Another student wishes to check the conclusion by repeating the experiment with 12.5 cm^3 of cold water.

Suggest two conditions which he should keep the same so that the comparison will be fair.

1.

 2.

[2]

- (e) Scientists in an industrial laboratory wish to use this experiment as a model of a heat exchanger, which transfers thermal energy between liquids.

Suggest **two** different improvements to the apparatus which would make the heating of the cold water more efficient.

For your **first** suggestion, explain why it would be an improvement.

suggestion 1

explanation

.....

suggestion 2

[3]

[Total: 8]

5 The IGCSE class is investigating the cooling of water.

A student cools some water by four different methods.

Experiment A (cooling with stirring)

(a) The student pours approximately 200 cm³ of hot water into a beaker.

She measures the temperature θ_1 . Fig. 2.1 shows the thermometer.

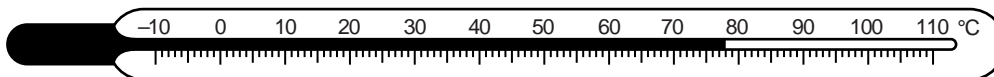

Fig. 2.1

Write down the temperature θ_1 shown on the thermometer in Fig. 2.1.

$\theta_1 = \dots\dots\dots$ [1]

(b) The student stirs the water for one minute. She then records the temperature θ_2 of the water.

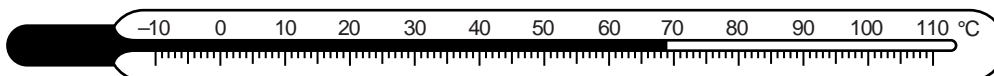

Fig. 2.2

(i) Write down the temperature θ_2 shown on the thermometer in Fig. 2.2.

$\theta_2 = \dots\dots\dots$

(ii) Calculate the temperature difference ($\theta_1 - \theta_2$).

$(\theta_1 - \theta_2) = \dots\dots\dots$ [1]

Experiment B (cooling with pouring)

(c) The student starts again with approximately 200 cm³ of hot water at the same initial temperature θ_1 .

She carefully pours the water from the beaker into another beaker. She pours the water back into the first beaker. She repeats this process four times.

She measures the temperature θ_3 of the water. Fig. 2.3 shows this temperature.

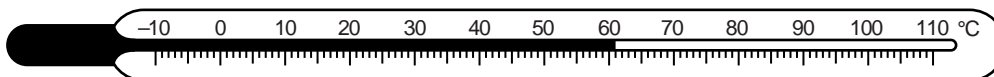

Fig. 2.3

(i) Write down the temperature θ_3 shown on the thermometer in Fig. 2.3.

$$\theta_3 = \dots\dots\dots$$

(ii) Calculate the temperature difference ($\theta_1 - \theta_3$).

$$(\theta_1 - \theta_3) = \dots\dots\dots [1]$$

Experiment C (cooling with a lid) and Experiment D (cooling without a lid)

(d) The student pours approximately 200 cm^3 of the hot water into each of two beakers. The initial temperature of the water in each beaker is θ_1 .

She places a lid on one of the beakers. She allows both beakers to cool for 5 minutes.

At the end of the cooling period, she calculates the temperature differences.

$$\text{temperature difference of C (with a lid) = } \dots\dots\dots 11^\circ\text{C}$$

$$\text{temperature difference of D (without a lid) = } \dots\dots\dots 31^\circ\text{C}$$

Rank the experiments **A**, **B**, **C** and **D** in order, with the one that produced the greatest temperature drop first.

- greatest temperature drop 1.
 - 2.
 - 3.
 - smallest temperature drop 4.
- [1]

(e) If this laboratory investigation is to be repeated many times to check the results, suggest two conditions that should be kept constant in order to provide reliable results.

- 1.
 - 2.
- [2]

(f) A student complains that the investigation is not a fair comparison.

Suggest one way in which the investigation could be more fair.

.....
..... [1]