

Electrical Circuits

Question Paper 6

Level	IGCSE
Subject	Physics
Exam Board	CIE
Topic	Electricity and Magnetism
Sub-Topic	Electrical Circuits
Paper Type	Alternative to Practical
Booklet	Question Paper 6

Time Allowed: 54 minutes

Score: /45

Percentage: /100

1 The IGCSE class is investigating the resistance of a wire.

The circuit is shown in Fig. 3.1.

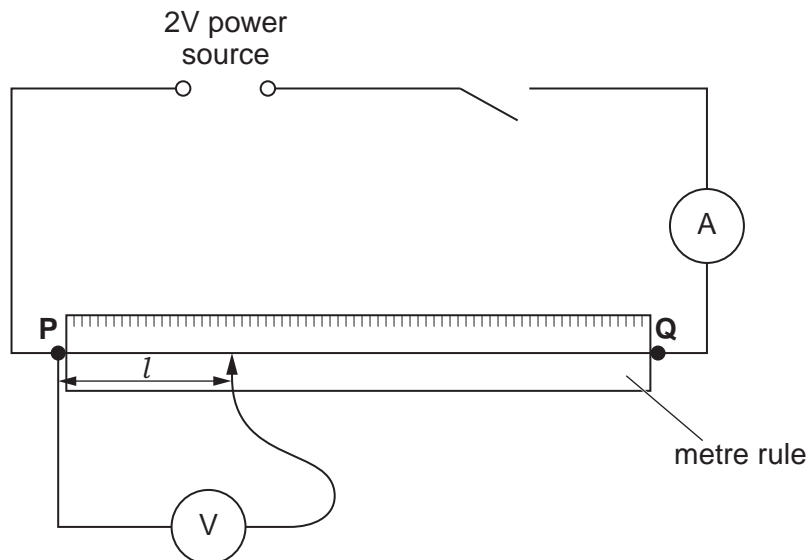

Fig. 3.1

(a) A student measures and records in Table 3.1 the current I in the circuit and the potential difference V across a length $l = 0.250$ m of wire PQ.

She repeats the procedure using l values of 0.500 m and 0.750 m.

- (i) Complete the heading for each column of the table.
- (ii) Calculate the resistance R of each length l of the wire using the equation $R = \frac{V}{I}$.
Record the values of R in the table.

Table 3.1

$l/$	$V/$	$I/$	$R/$
0.250	0.54	0.32	
0.500	1.10	0.32	
0.750	1.61	0.32	

- (b) Use numbers from the table to suggest and justify a relationship between the length l of the wire and its resistance R . Show your working.

relationship

.....

justification

.....

..... [3]

- (c) Use the results to predict the resistance of a 1.50m length of the same wire. Show your working.

prediction [2]

- (d) Another student proposes that the accuracy of the experiment would be improved by using a 12V power source.

Suggest two effects that this might have on the experiment.

1.

.....

2.

..... [2]

[Total: 11]

2 The IGCSE class is investigating the effect of the length of resistance wire in a circuit on the potential difference across a lamp.

(a) Fig. 3.1 shows the circuit without the voltmeter. Complete the circuit diagram to show the voltmeter connected in the circuit to measure the potential difference across the lamp.

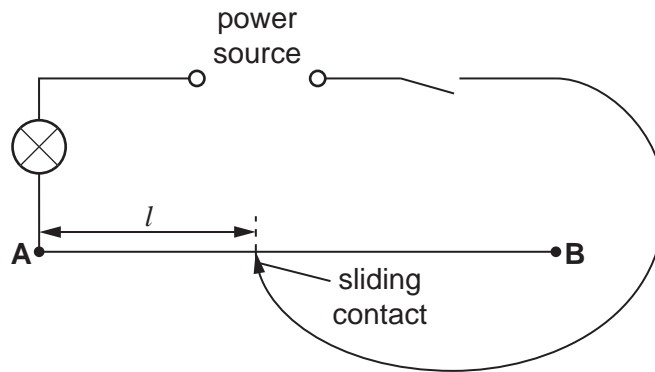

Fig. 3.1

[2]

(b) A student switches on and places the sliding contact on the resistance wire at a distance $l = 0.200\text{ m}$ from end A. He records the value of l and the potential difference V across the lamp. He then repeats the procedure using a range of values of l . Table 3.1 shows the readings.

Table 3.1

l/m	V/V	$\frac{V}{l}$
0.200	1.67	
0.400	1.43	
0.600	1.25	
0.800	1.11	
1.00	1.00	

- (i) For each pair of readings in the table calculate and record in the table the value of $\frac{V}{l}$.
- (ii) Complete the table by writing in the unit for $\frac{V}{l}$.

[3]

- (c) A student suggests that the potential difference V across the lamp is directly proportional to the length l of resistance wire in the circuit. State whether or not you agree with this suggestion and justify your answer by reference to the results.

Statement

Justification

.....[2]

- (d) State one precaution that you would take in order to obtain accurate readings of V in this experiment.

.....

.....

.....[1]

3 The IGCSE class is determining the resistances of lamps in different circuit arrangements.

The first circuit is shown in Fig. 3.1. This is Circuit 1.

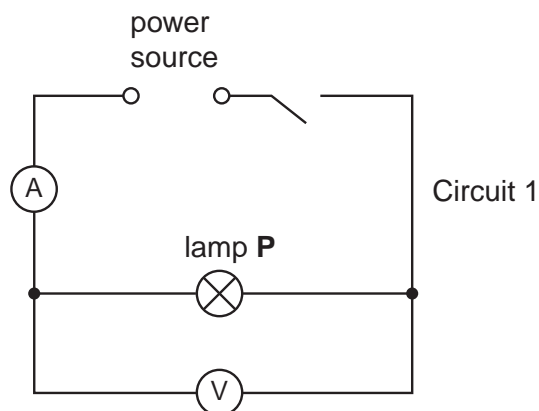

Fig. 3.1

A student measures the current I in the circuit and the p.d. V across lamp **P**. He then replaces lamp **P** with lamp **Q** to set up Circuit 2 (not shown) and records the readings of current I and potential difference V .

He then returns lamp **P** to the circuit so that lamps **P** and **Q** are in parallel with each other. This is Circuit 3. He again records the readings of current I and potential difference V . All the readings are in Table 3.1.

Table 3.1

	$V/$	$I/$	$R/$
Circuit 1	1.9	0.31	
Circuit 2	1.8	0.30	
Circuit 3	1.9	0.61	

(a) Draw a diagram of Circuit 3 using standard circuit symbols.

- (b) (i) Calculate the resistance R of the lamp arrangement for each circuit, using the equation $R = V/I$.

Record the values of R in Table 3.1.

- (ii) Complete the column headings in the table. [3]

- (c) A student suggests that the resistance of lamp **P** added to the resistance of lamp **Q** should be equal to the combined resistance of the two lamps when arranged in parallel in Circuit 3. State whether or not the results in the table support this suggestion and justify your answer **with reference to the results**.

Statement

Justification

.....

..... [2]

- 4 The IGCSE class is investigating the current in a circuit when different resistors are connected in the circuit.

The circuit is shown in Fig. 3.1. The circuit contains a resistor **X**, and there is a gap in the circuit between points **A** and **B** that is used for adding extra resistors to the circuit.

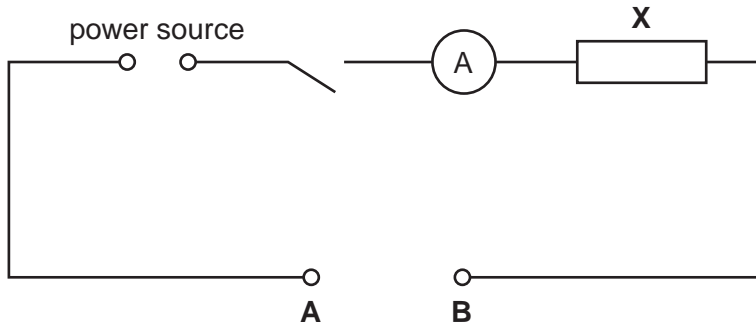

Fig. 3.1

- (a) A student connects points **A** and **B** together, switches on and measures the current I_0 in the circuit.

The reading is shown on the ammeter in Fig. 3.2.

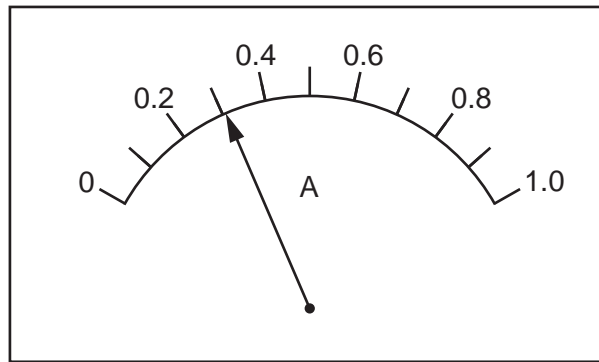

Fig. 3.2

Write down the ammeter reading.

$I_0 = \dots\dots\dots [1]$

- (b) The student connects a $3.3\ \Omega$ resistor between points **A** and **B**, switches on and records the current I . He repeats the procedure with a $4.7\ \Omega$ resistor and then a $6.8\ \Omega$ resistor.

Finally he connects the $3.3\ \Omega$ resistor and the $6.8\ \Omega$ resistor in series between points **A** and **B**, and records the current I .

- (i) Complete the column headings in the table. [1]

$R/$	$I/$
3.3	0.23
4.7	0.21
6.8	0.18
	0.15

- (ii) Write the combined resistance of the $3.3\ \Omega$ resistor and the $6.8\ \Omega$ resistor in series in the space in the resistance column of the table. [1]
- (c) Theory suggests that the current will be $0.5 I_0$ when the total resistance in the circuit is twice the value of the resistance of resistor **X**. Use the readings in the table, and the value of I_0 from (a), to estimate the resistance of resistor **X**.

estimate of the resistance of resistor **X** = [2]

- (d) On Fig. 3.1 draw two resistors in parallel connected between **A** and **B** and also a voltmeter connected to measure the potential difference across resistor **X**. [3]

[Total: 8]

5 The IGCSE class is investigating the potential difference across a resistor.

Fig. 3.1 shows the circuit used.

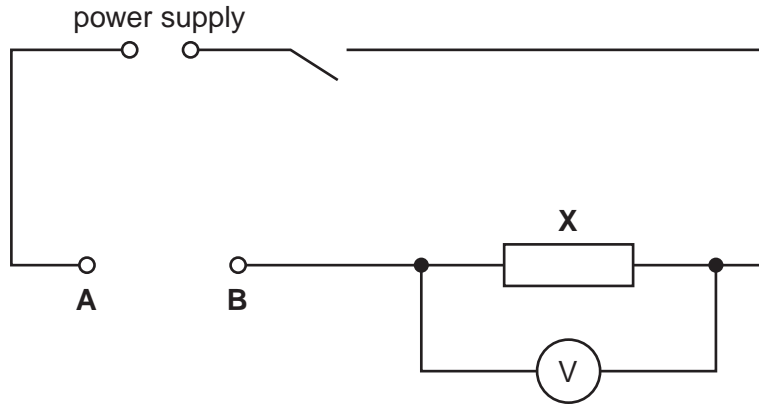

Fig. 3.1

The circuit contains a resistor **X**. There is a gap in the circuit between points **A** and **B** that is used for adding extra resistors to the circuit.

(a) A student connects points **A** and **B** together, switches on and measures the potential difference V_0 across resistor **X**. Fig. 3.2 shows the voltmeter scale.

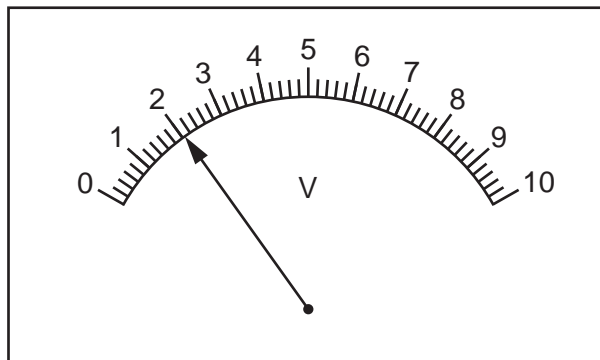

Fig. 3.2

Write down the value of potential difference V_0 shown on Fig. 3.2.

$V_0 = \dots\dots\dots$ [1]

- (b) The student does not change the position of the voltmeter in the circuit. She connects a 3.3Ω resistor between points **A** and **B** and records in Table 3.1 the resistance R of the resistor. She switches on and records the potential difference V across the resistor **X**.

She repeats the procedure with each of two other resistors and finally with the 3.3Ω and 6.8Ω resistors connected in series with each other.

- (i) Complete the column headings in the table.

Table 3.1

$R/$	$V/$
3.3	1.42
4.7	1.29
6.8	1.14
	0.95

- (ii) In the space provided in Table 3.1, write the combined resistance of the 3.3Ω and 6.8Ω resistors connected in series with each other. [2]

- (c) Plot the graph of V/V (y-axis) against R/Ω (x-axis). Begin both axes at 0.

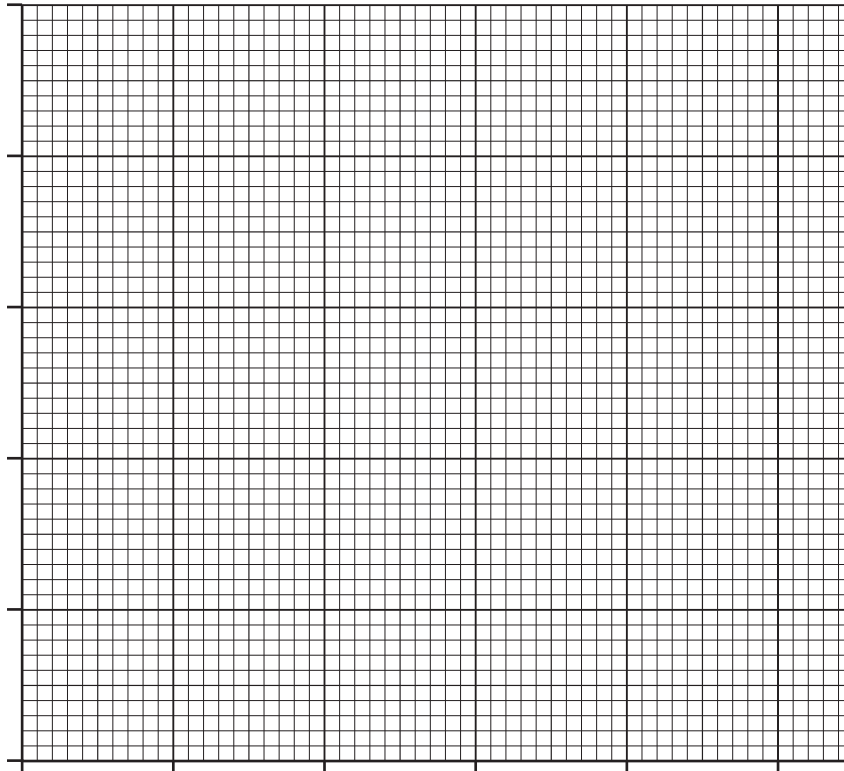

[5]

- (d) Use the graph to estimate the value of the potential difference V when $R = 0\Omega$. Show clearly on the graph how you obtained your result.

$V = \dots\dots\dots$ [2]